



Li-Ion 0.2Nm
18 mm, ~48 DB
Up to 48"x60"



Li-Ion 1.1Nm
25 mm, ~46 DB
Up to 84"x84"



Li-Ion Q2.0Nm
28 mm, ~44 DB
Up to 120"x120"

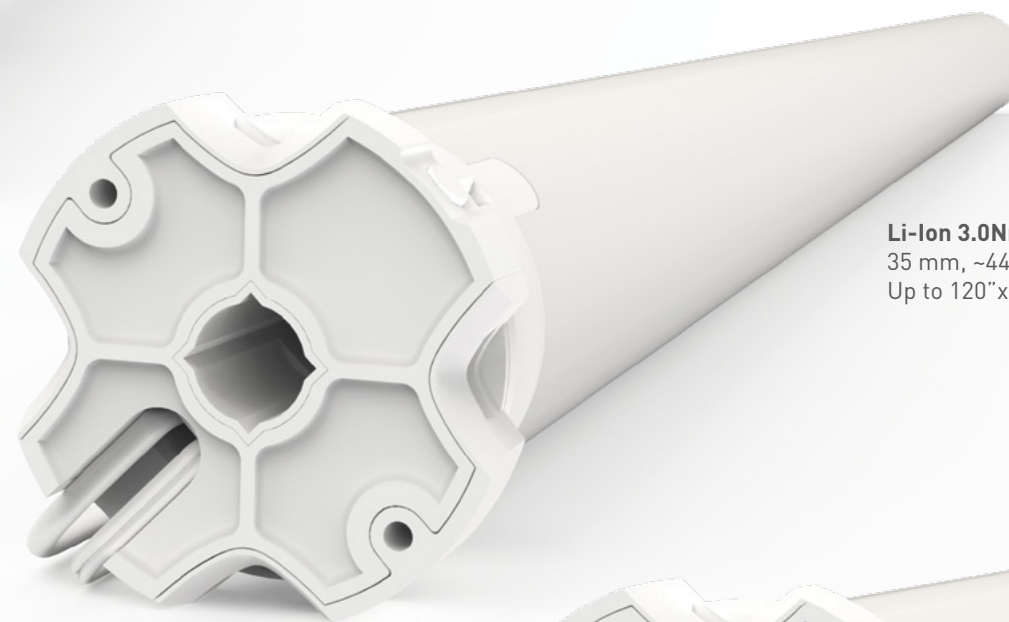

Li-Ion 3.0Nm & Q3.0Nm
35 mm, ~44 DB
Up to 120"x120"

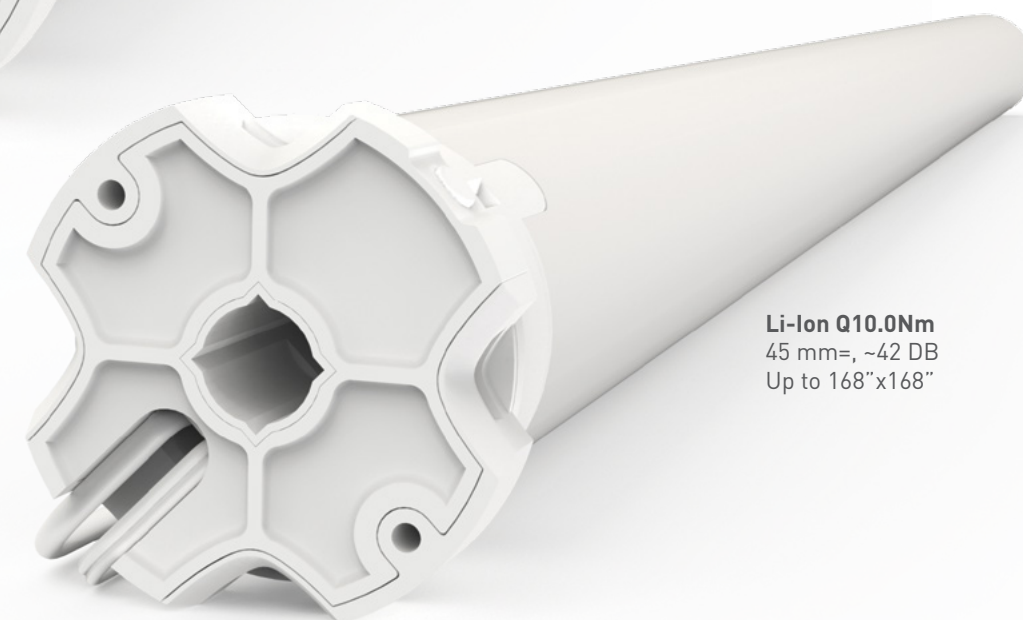

Li-Ion Q10.0Nm
45 mm, ~42 DB
Up to 168"x168"

Light sensing automatically manages daylighting at each window, minimizing reliance on and costs of artificial light.

AUTOMATE™ LI-ION

Automate's™ core motor line, Li-Ion, utilizes state of the art lithium ion battery technology integrated with the shades.

No wires for Easy Retrofit

Extended battery life with 500 expected up/down cycles per charge

Rechargeable from 12v wall charger

No bulky, external battery pack



BATTERY
POWERED



LEVEL
CONTROL



FAVORITE
POSITION



SELECTABLE
RPM



QUIET
OPERATION

LOW LIGHT SOLAR

Upgrade Li-Ion motors to include Automate's industry leading low light harvesting solar panel for a completely off-grid system that virtually never needs attention.

